

Short-circuit isolation in XP95 and Discovery fire detection systems

THE REQUIREMENT FOR ISOLATION

Analogue addressable fire detection systems are usually designed as loops, with the connecting wires starting and finishing at the control panel. Detectors and interfaces are connected at intervals along the cables. Depending on the local regulations, manual call points and sounders are connected either to the same loop or to other, dedicated loops. Spurs may be connected at any point of the loop, either directly from the loop wires or from an interface such as a Zone Monitor.

Short circuits do not occur very often but, when they do, the consequences can be serious, possibly making the affected loop entirely inoperative. It is for this reason that isolating circuits have been designed and incorporated into various devices that are connected to the loop. The purpose of these isolating circuits is to protect the loop in the event of a short circuit by disconnecting the part of the loop where the short circuit has occurred. When the short circuit fault has been rectified, the isolating circuitry reconnects the affected section of the loop.

FEATURES OF ISOLATING CIRCUITS

Isolating circuits are delivered as stand-alone isolators with their own mounting bases or as printed circuit boards in a version of the detector mounting bases known as 'isolating bases'. Isolating circuits are also fitted to interfaces such as Input/Output Units or Sounder Control Units. (Table 3).

Isolating circuits are intended for use with XP95 and Discovery detectors and interfaces. Isolating circuits are polarity sensitive and normally switch the negative line of the loop.

Apollo isolating circuits allow the connection of between one and twenty detectors or the equivalent load between isolators. (See 'Table 3' overleaf.)

Detectors fitted to isolating bases and interfaces with built-in isolating circuits remain operative when an adjacent loop section is in the isolated state. The isolated state is normally indicated by an illuminated yellow LED on the isolating unit.

OPERATING PRINCIPLES

Under normal operating conditions the isolating circuit provides a low resistance of 0.2Ω in either direction. If the loop voltage falls to $14V(+0.8/-0.4V)$ the isolator will switch from the closed state to the open state in order to isolate the loop 'in' and 'out' lines.

The isolated section is tested every four seconds with a current pulse and is automatically re-connected at a pre-set load resistance value (see 'Technical Data').

The current pulses are drawn from the loop and it is important for correct operation of the system that the pulse load be included in the loop calculation made for any system.

ISOLATOR TYPE

Two types of isolating circuit are used in Apollo products: one is the original circuit known as 20D which has been in use since the introduction of XP95. The other isolating circuit was developed in order to reduce the test current which is applied to isolated sections of the loop. It is known as the '20I' isolator and has the advantages of reducing the test current by two-thirds. In other respects the capabili-



© Apollo Fire Detectors Ltd 2000 - 2006



INVESTOR IN PEOPLE



Assessed to ISO 9001: 2000
Quality Systems Certificate number 010



36 Brookside Road, Havant, Hampshire PO9 1JR, England.

Tel: +44 (0)23 9249 2412 Fax: +44 (0)23 9249 2754 Website: www.apollo-fire.co.uk Email: sales@apollo-fire.co.uk

ties of the isolating circuits are very similar although some of the higher current devices are not so easily powered up. Ratings are therefore given for both isolating circuits.

The table gives the loadings possible with both 20D and 20i isolating circuits.

PANEL COMPATIBILITY

Control panels that are registered Apollo compatible are also compatible with Apollo isolating circuits but it is essential that compatibility of panel and isolating device be fully established when designing a fire detection system. Apollo offers a software program with which the viability of a design can be checked. The program, LoopCalc, may be downloaded from Apollo's website: www.apollo-fire.co.uk

If the panel has built-in isolators, it is essential that

isolators connected to the loop switch the same line—positive or negative—as the panel isolators. Although the majority of systems are designed to isolate the negative line, Apollo can supply isolators that switch the positive line. (These are distinguished by having a clear LED which emits yellow light in the isolated state.)

Note: all detectors and other devices between any two isolators or isolating devices should be in the same fire zone, because communications with them will be lost if a short-circuit occurs between isolators.

Load Calculation Diagram

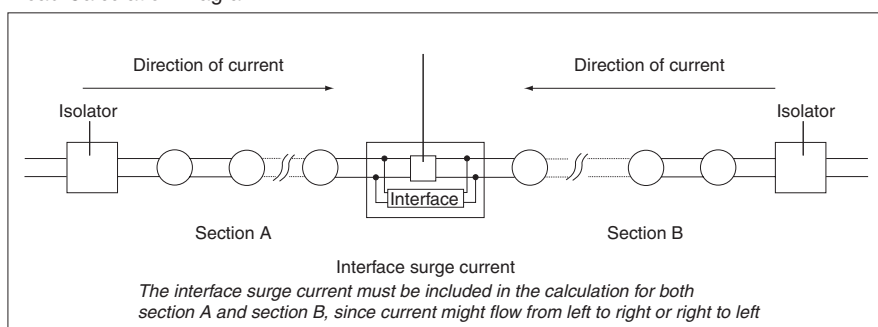

Fig 1 Diagram to show loading of an isolated loop

Isolating Device	Part no	Literature
XP95 Isolator Base	55000-720 45681-211	PP1039 Product Guide
XP95 Isolating Base	45681-321	PP1039 Product Guide
XP95 Switch Monitor with Isolator	55000-843	PP2084 PIN Sheet
XP95 Switch Monitor Plus with Isolator	55000-841	PP2083 PIN Sheet
XP95 Input/Output Unit with Isolator	55000-847	PP2092 PIN Sheet
XP95 Output Unit with Isolator	55000-849	PP2093 PIN Sheet
XP95 Sounder Control Unit with Isolator	55000-852	PP2094 PIN Sheet
Call Point with Isolator	55100-908	
Integrated Base Sounder	45681-277	PP2209 PIN Sheet
Sounder Beacon Base with Isolator	45681-330	PP2235 PIN Sheet

Table 1 Publications available for products with isolating circuits

Technical Data

	20I	20D	EN54-17 parameter
Electrical			
XP95/Discovery loop voltage	17V–28V plus 5–9V protocol pulses		$V_{min} - V_{max}$
Maximum power-up time	30ms	10ms	
Maximum loop current continuous short-circuit switching	1.0A 3.0A		I_{Cmax} I_{Smax}
Quiescent current at 18V at 24V at 28V	23µA 35µA 45µA	23µA 35µA 45µA	I_{Qmax}
Maximum 'on' resistance	0.2Ω		Z_{Cmax}
Isolation specification			
Isolating voltage	13.6V–14.8V	13.6V–14.8V	$V_{SOmin} - V_{SOmax}$
Re-connect voltage	12.9–17.5V DC	12.9–17.5V DC	$V_{SCmin} - V_{SCmax}$
Loop test current in isolated state	12.0–15.5mA	35–50mA	$I_{min} - I_{max}$
Current in isolated state at 18V at 24V at 28V	16.0mA DC 18.5mA DC 21.0mA DC	4.0mA DC 5.4mA DC 6.4mA DC	
De-isolation test impedance limit spur connection loop connection	950–1350Ω 475–675Ω	300–420Ω 150–210Ω	$Z_{SCmin} - Z_{SCmax}$
Environmental			
Operating temperature	–20° C to +60° C		
Storage temperature	–30° C to +80° C		
Operating humidity	0%–95%RH (no condensation or icing)		
Design environment	Indoor use only		
CE marked			

Table 2

LOAD CALCULATION		
Device	20I	20D
XP95 Optical Detector	1	1
XP95 Ionisation Detector	1	1
XP95 Multi-Sensor Detector	1	1
XP95 Heat Detector	1	1
XP95 High Temperature Heat Detector	1	1
XP95 MCP	1	1
XP95 I.S Optical Detector	1	1
XP95 I.S Ionisation Detector	1	1
XP95 I.S Heat Detector	1	1
XP95 I.S MCP Detector	1	1
XP95 Protocol Translator	1	1

Discovery Optical Detector	1	1
Discovery Ionisation Detector	1	1
Discovery Multi-Sensor	1	1
Discovery Heat Detector	1	1
Discovery CO Detector	1	1
Discovery MCP	1	1
Intelligent Base Sounders (85dB)	1	1
Intelligent Base Sounders (92dB)	1	1
Integrated Base Sounders	1	1
Integrated Base Sounders (with isolator)	1	1
Loop Powered 100dB Sounders (inc W/P)	2	2
Loop Powered Beacon	3	3

Device	20I	20D
Ancillary Base Sounder	0	0
XPlorer Base Sounder	0	0
Beam Detector - Transmitter	12	7
Beam Detector - Receiver and Interface	32	20
Reflective Beams	10	5
Flame Detectors	12	20
XP95 I/O Unit	4	4
XP95 Three Channel I/O Unit	7	7
XP95 Mains I/O Unit	4	4
XP95 Output Unit	3	3
XP95 Mini Switch Monitor	3	3
XP95 Mini Switch Monitor with Interrupt	4	4
XP95 Switch Monitor	3	3
XP95 Switch Monitor Plus	3	3
XP95 Zone Monitor	10	7
XP95 Sounder Control Unit	3	3
XP95 I/O Unit (with isolator)	4	4
XP95 Three Channel I/O Unit (with isolator)	7	7
XP95 Output Unit (with isolator)	3	3
XP95 Switch Monitor (with isolator)	3	3
XP95 Switch Monitor Plus (with isolator)	3	3
XP95 Zone Monitor (with isolator)	10	7
XP95 Sounder Control Unit (with isolator)	3	3
XP95 DIN-Rail I/O Unit	4	4
XP95 DIN-Rail Output Unit	3	3
XP95 DIN-Rail Switch Monitor	3	3
XP95 DIN-Rail Switch Monitor Plus	3	3
XP95 DIN-Rail Zone Monitor	3	3
XP95 DIN-Rail Sounder Control Unit	3	3
XPlorer Switch Monitor	3	3
Xplorer Output Unit	3	3

Table 3 Load calculation