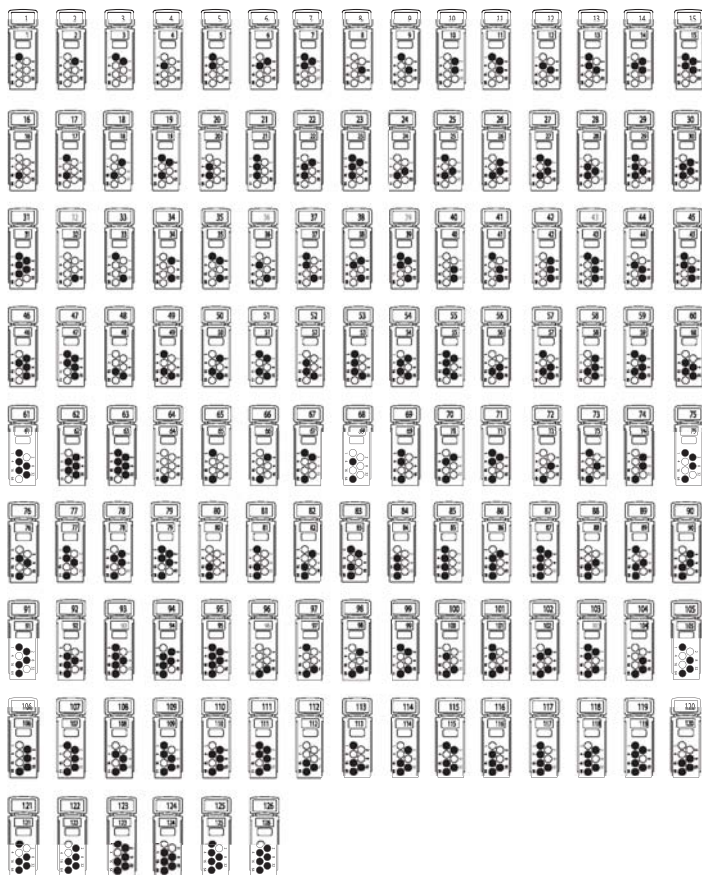

XP95 and Discovery address setting table

Select the desired address and remove the pips indicated in black. Remove pips with a small screwdriver.

**Technical data**

This depends on the model of detector head fitted to the duct smoke detector. Please refer to the product guide for the individual head for full details.

The relay is specified as 1A at 30V DC, resistive load.

Troubleshooting

Before investigating individual units for faults, it is important to check the system wiring is fault free. Earth faults on data loops may cause communication errors.

Fault Finding

Problem	Possible cause
Fault on control panel	Incorrect wiring Detector not fitted Duct detector housing cover incorrectly fitted Incorrect address (XP95/Discovery only) Incorrect detector type (XP95/Discovery only)
Constant alarm	Smoke present in duct Contaminated detector
Detector does not alarm under test	Sampling tubes fitted incorrectly Detector baffle not fitted Duct detector housing cover incorrectly seated Sampling tube (air in) incorrectly sealed Duct detector housing incorrectly seated on duct Incorrect wiring



Duct Smoke Detector Installation Guide

General

Duct smoke detectors provide early detection of smoke in the air moving through heating and ventilation (HVAC) ducts in commercial and industrial premises. Their purpose is to prevent the recirculation of smoke from an area on fire to areas unaffected by the fire.

A duct smoke detector comprises a plastic housing with two air tubes (inlet and exhaust) and a mounting base for either a conventional or an analogue addressable point smoke detector. Duct detector part no 53546-021 has a mounting base for Series 65 detectors, part no 53546-023 has a mounting base for Orbis detectors and part no 53546-022 has a mounting base for XP95 or Discovery detectors. Part nos 53546-021 and 53546-023 are fitted with volt-free relay contacts that may be used as required.

Both ionisation and optical detectors may be used in the duct detectors. See overleaf for a list of suitable detectors

Caution: duct smoke detectors are for indoor use only and are not designed to offer early warning of fire or to be used as a replacement for a standard fire detection system.

When using the S65 or Orbis duct detector on a conventional panel, it is recommended that only one unit be connected per zone.

Note: when installing duct detectors observe local codes of installation such as BS5839-1 or NFPA 90A

Principles of operation

The duct smoke detector is fitted to the side, the top or the bottom of the ventilation duct and has two tubes which extend into the air duct through holes in the duct wall. The perforated inlet tube which spans the duct is placed in the airflow upstream of the exhaust tube which causes a pressure differential in the duct detector. Air is sucked up the inlet, across the detector and exhausted back into the air duct. The duct detector may be used in air speeds of between 0.5 and 20m/s.

Sampling tubes

The duct smoke detector is designed to operate in ducts with a width of between 300mm and 3 metres. An inlet tube of 360mm, suitable for duct widths up to 560mm, is supplied as standard. This tube needs to be attached only to the duct detector housing. Longer inlet tubes for wider ducts may be ordered separately:

300—750mm Part no 53541-170

750—1500mm Part no 53541-171

1500—3000mm Part no 53541-172

Tubes in duct widths above 560mm should be long enough to reach from one side of the duct to the other and it may be necessary to use a tube that is too long and cut it to slightly more than the duct width. If the tube is longer than 90cm it needs to be supported on both sides by a hole that should be cut in the opposite wall of the air duct, allowing the tube to protrude slightly. *The tube must be closed with the small red bung provided.* The exhaust tube does not need to extend across the duct and is therefore supplied at a fixed length.

Siting and mounting the duct smoke detector

- To minimise the impact of air turbulence and stratification on performance a duct smoke detector should be located as far as possible downstream from any obstruction (ie, deflector plates, elbows, dampers, etc). In all situations confirmation of velocity and pressure differential within specifications is required.

A uniform non-turbulent (laminar) airflow between 0.5 and 20m/s must be present in the air duct. The pressure differential between inlet (high pressure) and exhaust (low pressure) tubes should be between 0.025 and 3mbar.

- Locate the detector so that it is easy to view and service it.
- If installing the detector in the return air side of the duct, locate it at a point where it will not be diluted with outside air.
- If detectors are fitted downstream of filters the filters should be kept clean. If they are blocked with dirt the duct smoke detector will not function properly.
- If possible, install duct smoke detectors upstream of air humidifiers and downstream of dehumidifiers.
- To minimise false alarms avoid mounting the detector in areas of extreme high or low temperatures, in areas of high humidity or in areas containing gases or high amounts of dust.
- Remove the paper backing from the mounting template supplied with the detector and fix the template to the air duct at the chosen location. Using the template as a guide drill two mounting holes 2.5mm diameter for the two 6x12mm screws supplied in the installation kit.
- Drill 32mm holes for the sampling tubes, again using the template as a guide. De-burr all holes.
- Mount the detector housing to the air duct and fix with the two 6x12mm screws. Install the inlet tube, making sure the holes face the air flow. The end of the inlet tube may need to be supported as described in the section 'Sampling Tubes'. Tighten the latch screw to secure the tube.

Wiring the duct smoke detector

Connect the line or loop wires as shown in the diagrams below.

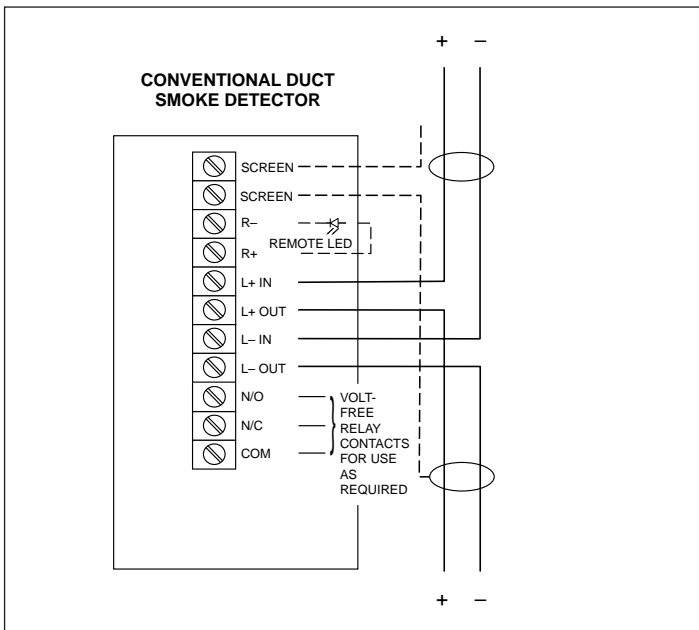

Fig 1. Wiring diagram for Conventional Duct Smoke Detectors

If a diode is to be fitted for detector head removal, it should be connected across L+ IN and L+ OUT.

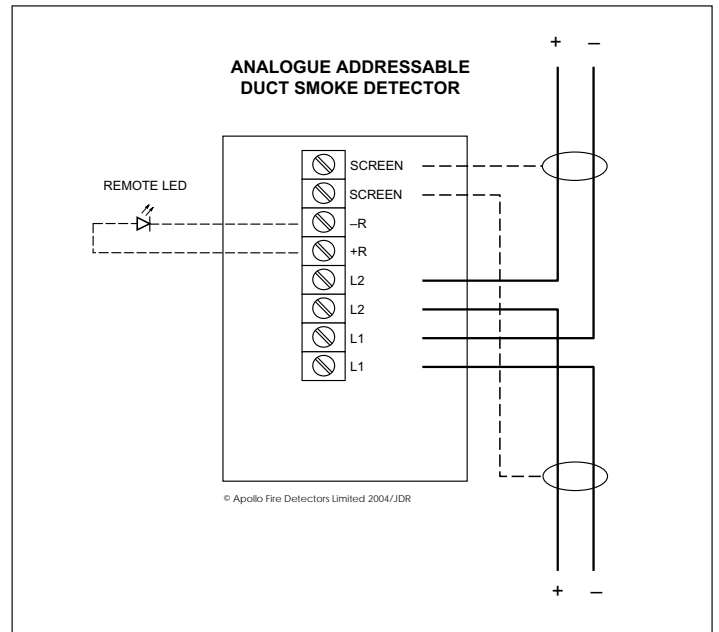

Fig 2. Wiring diagram for Analogue Addressable Duct Smoke Detector

Fitting the detector head

Duct smoke detector part no 53546-021 is designed to accept a Series 65 head. The following heads may be used:

	Ionisation smoke	Optical smoke
Series 65	55000-217	55000-317
Series 65 with flashing LED	55000-216	55000-316

Duct smoke detector part no 53546-023 is designed to accept an Orbis head. The following head may be used:

	Optical smoke
Orbis	ORB-OP-12001-APO

Duct smoke detector part no 53546-022 is designed to accept an analogue detector head. The following heads may be used:

	Ionisation smoke	Optical smoke
XP95	55000-500, 520	55000-600, 620
Discovery	58000-500	58000-600
For address details see section 'Address setting' overleaf		

After fitting the detector head fit the baffle. Locate the edge of the baffle in the slots in the side wall of the housing.

Functional test

When the detector head has been fitted a test should be carried out using smoke test gas part no 29600-225. Insert the test gas nozzle into the test point on the unit cover. Press can against cover to release gas into chamber. *Caution: do not spray gas for more than 1/2 second.*

After 15-20 seconds a conventional detector head should change to the alarm state and an analogue detector should transmit an analogue value of 55 or greater. In both cases the detector LED should illuminate. Allow time for the gas to disperse before resetting the detector.

Address setting

If duct detector 53546-022 is used the address of the detector must be set before fitting the detector head. The address of the detector is set using the XPRT card. The address settings are shown in the diagram overleaf.