



XP95 DIN-Rail Mounted Dual Isolator Installation Guide

General

The XP95 DIN-Rail Mounted Dual Isolator, part no. 55000-802, is designed to be mounted in an enclosure, either clipped onto a standard 35mm DIN rail (DIN 46277) or fixed directly to the enclosure using two 4mm screws.

The installation must conform to BS5839 (or applicable local codes) and be carried out such that the unit is not subjected to:

Exposure to risk of mechanical damage

Unauthorised modification or interference

Exposure to moisture, dust and foreign bodies

Exposure to temperatures exceeding the maximum ambient

Installation

1. Run the cables from the XP95 loop into the unit. Ensure that earth continuity is maintained.
2. *Either* clip the unit to the standard 35mm DIN rail (DIN 46277)
Or fully extend the latches from the base of the unit and secure the unit to the enclosure using two 4mm screws with a spacing of 90mm.

Wiring Details

All wiring terminals accept solid or stranded cables up to 2.5mm².

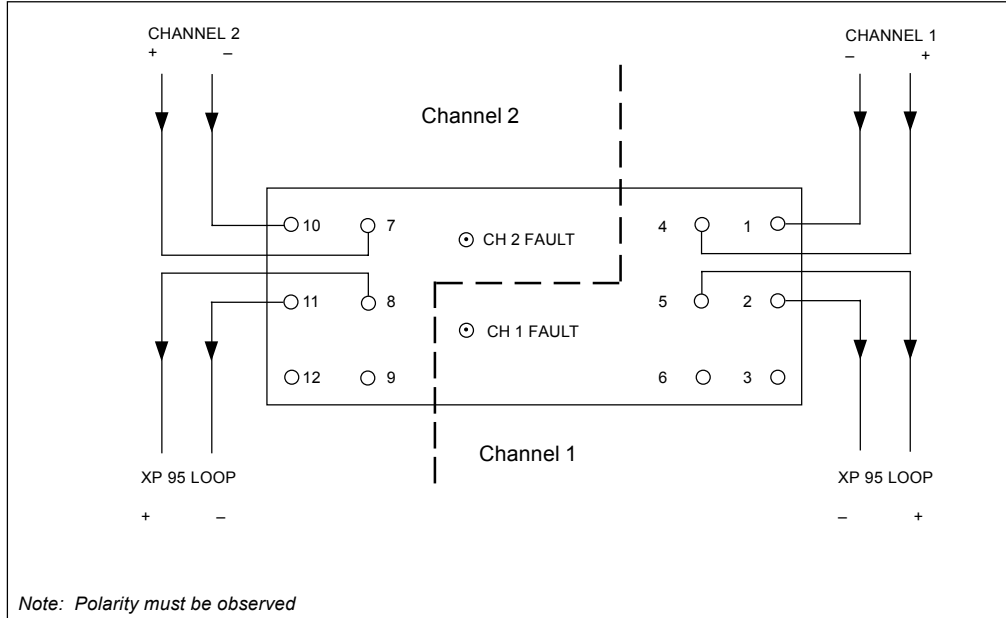

Electrical Characteristics

Max supply voltage	30V DC, 39V peak
Quiescent current	47µA at 28V
	4mA when isolating
Max current (through loop)	1A continuous, 3A peak
Isolating voltage	14V

Commissioning

Commission the fire detection system in accordance with local codes and the panel manufacturer's instructions. With the system in the normal operating condition, apply short-circuits to the loop wiring at selected points between isolators. Verify that isolators function correctly.

LED Indicators

- ☉ Ch 2 Fault Illuminated when loop wiring to Ch 2 is short-circuit
- ☉ Ch 1 Fault Illuminated when loop wiring to Ch 1 is short-circuit

Troubleshooting

Before investigating individual units for faults, it is important to check that the system wiring is fault free. Earth faults on data loops or interface zone wiring may cause communication error. Many fault conditions are the result of simple wiring errors. All connections to the unit should be checked. For a full technical description refer to the XP95 DIN-rail Mounted Dual Isolator Pin Sheet, PP2051.

Fault Finding

	Problem	Possible Cause
	Loop short-circuit, isolator LED not illuminated	Isolator connected in reverse polarity
	No supply on loop output	Incorrect isolator wiring
Unit does not isolate when loop shorted		Incorrect isolator wiring High resistance in loop wiring