

### Functional Test Data

OUTPUT BIT	FUNCTION	INPUT BIT	FUNCTION
2	NOT USED	2	NOT USED
1	ACTIVATE TEST	1	TEST ACTIVATED
0	SIMULATE FAULT	0	FAULT SIMULATION CONFIRMED

### Troubleshooting

Before investigating individual units for faults, it is very important to check that the *system* wiring is fault free. Earth fault on a data loop or any ancillary zone wiring may cause communication errors. Many fault conditions are the result of simple wiring errors. Check all connections to the unit first.

### Fault finding

Problem	Possible Cause
No response or missing	Incorrect address setting Incorrect loop wiring
Fault condition reported	Incorrect wiring
Analogue value unstable	Dual address Loop data fault, data corruption
Constant alarm	Incorrect end-of-line resistor Incorrect wiring



## XPlorer Switch Monitor Installation Guide

### General

The XPlorer Switch Monitor, part no 59000-820, is designed to monitor the state of one or more single-pole, volt-free contacts and should be mounted in an enclosure to comply with EMC regulations.

**Note: The XPlorer Switch Monitor is not designed for outdoor use unless it is mounted in a suitable weather-proof enclosure.**

### Mounting

1. Mount the unit as required with the screws provided.
2. Terminate all cables.
3. Set the address of the unit as shown on page 3.

## Wiring Details

All wiring terminals will accept solid or stranded cables up to 2.5mm<sup>2</sup>.

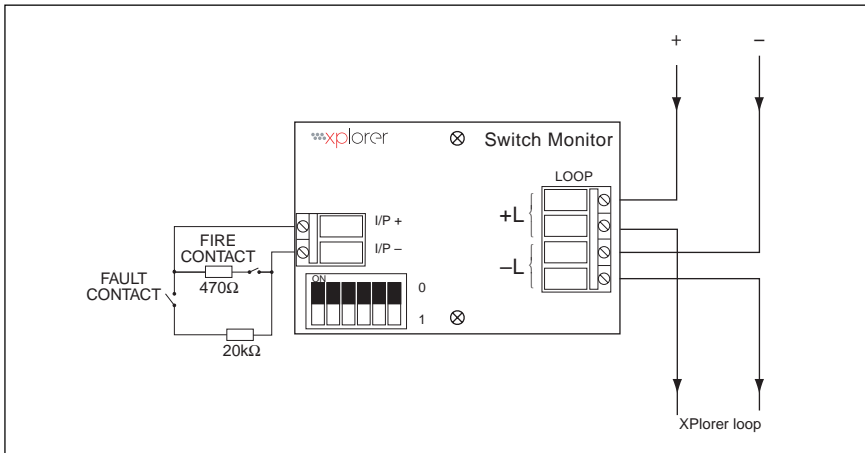

## Resistors

The fire contact resistor (470Ω) and the end-of-line resistor (20kΩ) are supplied with the switch monitor. The colour codings of the resistors are as follows:

470Ω yellow/violet/brown  
20kΩ red/black/orange

## Current consumption at 24V

switch-on surge, max 150ms 5mA  
quiescent 250μA

For a full technical specification of the Switch Monitor, please refer to the XPlorer Technical Guide PP2098.

## Address Setting

The address of the Switch Monitor is set using the six-segment DIL switch. Each segment of the switch must be set to "0" (ON) or "1" (OFF), using a small screwdriver or similar tool. A complete list of address settings is shown below.

addr	DIL switch setting	addr	DIL switch setting	addr	DIL switch setting	addr	DIL switch setting
	123456		123456		123456		123456
64	000000	80	000010	96	000001	112	000011
65	100000	81	100010	97	100001	113	100011
66	010000	82	010010	98	010001	114	010011
67	110000	83	110010	99	110001	115	110011
68	001000	84	001010	100	001001	116	001011
69	101000	85	101010	101	101001	117	101011
70	011000	86	011010	102	011001	118	011011
71	111000	87	111010	103	111001	119	111011
72	000100	88	000110	104	000101	120	000111
73	100100	89	100110	105	100101	121	100111
74	010100	90	010110	106	010101	122	010111
75	110100	91	110110	107	110101	123	110111
76	001100	92	001110	108	001101	124	001111
77	101100	93	101110	109	101101	125	101111
78	011100	94	011110	110	011101	126	011111
79	111100	95	111110	111	111101		

## Commissioning

It is important that the XPlorer Switch Monitor be fully tested after installation. An XP95 Test Set, part no 55000-870, may be used to carry out functional testing of individual units. It can also be used to perform data integrity tests of an entire system.