

**Specifications**

<b>Part Number</b>	55000-825	
<b>Compatibility identifier</b>	55000-825	
<b>Type</b>	Sounder control module	
<b>Style</b>	Face plate with screw terminals	
<b>Dimensions</b>	4½" x 4½" x 1"	
<b>Temperature range</b>	32°F to 120°F (0°C to 49°C)	
<b>Humidity</b>	10 to 93% RH Non-condensing	
<b>Wiring size</b>	24AWG - 14AWG	
<b>Signal line circuit (SLC)</b>	Supervised power limited	
<b>Working voltage</b>	17-28 VDC	
	<b>Modulation voltage</b>	5-9V (peak to peak)
	<b>Supervisory current</b>	1.3mA
	<b>Surge current</b>	7.5mA
	<b>Maximum operating current</b>	4mA
<b>Functional states</b>	<b>Analog level (Normal)</b>	16
	<b>Analog level (Trouble)</b>	4*

\* Local supply failure, notification appliance circuit short/open circuit or group address conflict.

**Notification appliance circuit (NAC)**

<b>Wiring styles</b>	Supervised power limited outputs Class A and Class B End-of-line supervisory resistor: 47KΩ, 0.5W (Class B only)
<b>External supply</b>	Connected between vext+ and vext- Monitored input (DC voltage supplies only)
<b>Max (NAC)</b>	Regulated 24VDC, 1A. Use a regulated power limited DC supply that is listed for fire protection applications. The maximum number of connected devices must be within the output rating.
<b>Max NAC Line Loss</b>	Maximum line loss when using a NAC supply from a control panel - refer to panel manufactures documentation regarding total allowable line losses. Maximum line loss when using a regulated supply (including wiring from regulated supply to module) - 4VDC when a 24VDC regulated power supply is used. Refer to fire control panel literature for details on how to achieve audio and visual synchronization.
<b>Max (Speakers)</b>	70.7 V rms, 500mA, with wire supervision capability as per NFPA requirements. The speakers used must be listed for fire protection applications.
<b>End-of-Line Resistors</b>	47KΩ (A UL listed end-of-line resistor is available from Apollo and can be ordered under part number 44251-146.

**Functional Test Data**

Output Bit	Function	Input Bit	Function
2	Group Address Control 1 = Group 0 = Individual	2	Group Address Confirmation 1 = Group 0 = Individual
1	Not used	1	Indicates Class Wiring 1 = Class B 0 = Class A
0	Sounder Control 1 = On 0 = Off	0	Sounder Status 1 = On 0 = Off

©Apollo Fire Detectors Ltd 1994-2009

Apollo Fire Detectors Ltd, 36 Brookside Road, Havant, Hants, PO9 1JR, UK  
Tel +44 (0)23 9249 2412 Fax +44 (0)23 9249 2754  
Email: techsales@apollo-fire.co.uk Website: www.apollo-fire.co.uk

In the USA: Apollo America, 821 Ulrich Ave, Louisville, KY 40219, USA  
Tel: (502) 964-6565 Fax: (502) 964-6229  
Email: infoUSA@apollo-fire.com Website: www.apollo-fire.com



## XP95A Sounder Control Module Installation Instructions

**General**

The XP95A Sounder Control Module, part no 55000-825, monitors and controls a circuit of alarm notification appliances or speakers. It is mounted on a plastic face plate for use with a 4" square or 2 gang electrical box (minimum depth 2½"). The module requires a separate 24V dc supply to power notification appliances.

In addition to individual Sounder Control Module operation, multiple modules can be controlled simultaneously as a group.

A red LED flashes in synchronization with the current pulse reply from the device.

*Note: the XP95A Sounder Control Module is designed for indoor use only.*

**Control Panel Compatibility**

The module has been listed by Underwriters Laboratories Inc. for details of compatible control panels contact Apollo Fire Detectors Limited. Please check fire control panel literature for compatible Apollo devices.

**Installation**

These products must be installed in accordance with the applicable NFPA standards, local codes and the authority having jurisdiction. Failure to follow these instructions may result in failure of devices to report an alarm condition. Apollo Fire Detectors Limited is not responsible for devices which are improperly installed, maintained and tested.

Before installing these products, check the continuity, polarity and resistance of all wiring. Check that the application is in accordance with the fire system drawings and conforms to all applicable code requirements.

1. Mount the electrical box as required and install all cables for termination. Ensure that cable shield/earth continuity is maintained.
2. Drill holes in the face plate corresponding to the holes on the mounting box selected (Fig 1).
3. Terminate all cables in compliance with local codes and regulations.
4. Set the address of the module as shown on page 3.
5. Gently push the completed assembly towards the mounting box and align the mounting holes. Secure the unit with the screws provided. **Do not overtighten the screws.**
6. Commission the module.

**Speakers**

If the Sounder Control Module is to be used to drive speakers, the jumper J1 (Fig 2) should be set as indicated. The external supply should be replaced by an audio amplifier with a maximum of 70.7 V rms with supervision capability as per NFPA 72. The speakers connected must be listed for fire protection applications.

**Notes**

1. Any power supply connected to the Vext I/P should be independent, regulated 24V dc, power limited and listed for fire protection with battery back-up capability.
2. All circuits are power limited except when used as a speaker circuit, if used remove the lower portion of the power limited label along the kiss cut. Use only limited energy cable types FPL, FPLR or FPLP on power limited circuits.

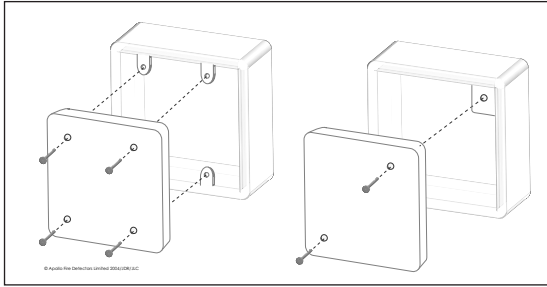

Fig 1. Mounting the XP95A Sounder Control Module

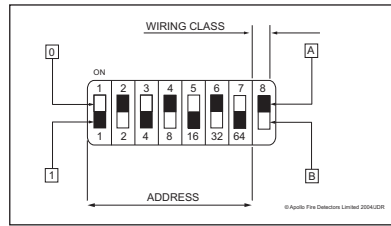

Fig 3. DIP Switch, S1

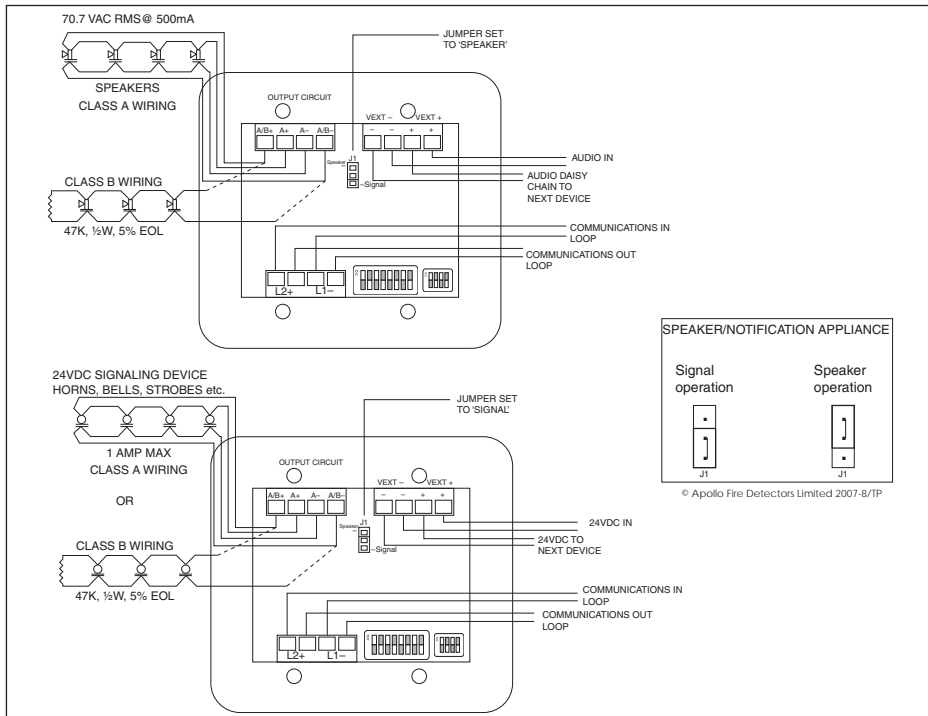

Fig 2. Wiring diagram for XP95A Sounder Control Module

**Address Setting**

Segments 1-7 of the DIP switch are used to select the address of the module. Each of the seven segments must be set to '0' (ON) or '1' (OFF) using a small screwdriver or similar tool. A complete list of address settings is shown below. (The eighth segment of the switch is used to select Class A or B wiring)

addr	DIP switch setting 1234567	addr	DIP switch setting 1234567	addr	DIP switch setting 1234567	addr	DIP switch setting 1234567	addr	DIP switch setting 1234567
1	1000000	11	1101000	21	1010100	31	1111100	41	1001010
2	0100000	12	0011000	22	0110100	32	0000010	42	0101010
3	1100000	13	1011000	23	1110100	33	1000010	43	1101010
4	0010000	14	0111000	24	0001100	34	0100010	44	0011010
5	1010000	15	1111000	25	1001100	35	1100010	45	1011010
6	0110000	16	0000100	26	0101100	36	0010010	46	0111010
7	1110000	17	1000100	27	1101100	37	1010010	47	1111010
8	0001000	18	0100100	28	0011100	38	0110010	48	0000110
9	1001000	19	1100100	29	1011100	39	1110010	49	1000110
10	0101000	20	0010100	30	0111100	40	0001010	50	0100110
51	1100110	61	1011110	71	1110001	81	1000101	91	1101101
52	0010110	62	0111110	72	0001001	82	0100101	92	0011101
53	1010110	63	1111110	73	1001001	83	1100101	93	1011101
54	0110110	64	0000001	74	0101001	84	0010101	94	0111101
55	1110110	65	1000001	75	1101001	85	11010101	95	1111101
56	0001110	66	0100001	76	0011001	86	0110101	96	0000011
57	1001110	67	1100001	77	1011001	87	1110101	97	1000011
58	0101110	68	0010001	78	0111001	88	0001101	98	0100011
59	1101110	69	1010001	79	1111001	89	1001101	99	1100011
60	0011110	70	0110001	80	0000101	90	0101101	100	0010011
101	1010011	111	1111011	121	1001111				
102	0110011	112	0000111	122	0101111				
103	1110011	113	1000111	123	1101111				
104	0001011	114	0100111	124	0011111				
105	1001011	115	1100111	125	1011111				
106	0101011	116	0010111	126	0111111				
107	1101011	117	1010111						
108	0011011	118	0110111						
109	1011011	119	1110111						
110	0111011	120	0001111						

**Group Address Setting**

In Group mode the Sounder Control Module responds to an additional address referred to as the 'group address', which is used to activate groups of Sounder Control Modules simultaneously. (The module continues to respond to its own individual address and report its status from that address in the normal way.) The group address is selected by the four-segment DIP switch S2 which is factory-set to 0000. A group address may be any spare address within - and only within - the range 112 to 126 inclusive. The required group address is set by moving one or more of the segments on the switch to '1' (OFF). The table shows the settings for the group address switch:

addr	DIP switch setting 1248	addr	DIP switch setting 1248
112	1111	121	0110
113	0111	122	1010
114	1011	123	0010
115	0011	124	1100
116	1101	125	0100
117	0101	126	1000
118	1001		
119	0001		
120	1110		

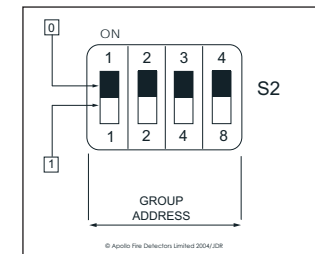

Fig 4. DIP Switch, S2